

CP 216s OD

System Components

Media Vessel (Qty.) Size	(2) 16" x 65"
Media Vessel Construction	Wrapped Polyethylene
Empty Bed Volume	6.55 ft ³
Media	4.0 ft ³ Non Solvent Cation Resin
Bed Depth / Free Board	47" / 18"
Riser Tube	1" ABS
Distributor Upper	0.014" Slots, ABS Basket
Lower	0.014" Slots, ABS Basket
Under bedding	0.75 ft ³ (75 lbs), ¼ x ⅛ Gravel
Regeneration Control	Non-electric Use Meter
Regeneration Type	Countercurrent
Meter Type	1.10 - 50.00 gpm Polypropylene Turbine (Kinetico Open Louver Flow Nozzle)

Inlet Water Quality

Pressure Range	25 – 125 psi Dynamic Pressure
Temperature Range	35 – 120° F
pH Range	5 – 10 SU
Free Chlorine Cl ₂ (Max.)	2.0 mg/L
Hardness as CaCO ₃ (Max.)	49 gpg

Operating Specs

Flow Range – Overdrive (15 / 30 psig)	35.0– 47.0 gpm
Flow Range – Alternating (15 / 30 psig)	23.0 – 33.0 gpm
Dimensions (Width x Depth x Height)	33" x 16" x 71.75"
Weight (Operating / Shipping)	1,185 / 665 lbs.

Connections

Inlet / Outlet Connections	Custom Adapter and E-clip (1 ½" Brass Sweat Fittings Included)
Drain Connection	0.625" Tube
Brine Line Connection	0.375" Tube
Power	None

System Part Numbers

CP 216s OD, 24" X 40" Brine Tank, Media Separate	11182A
CP 216s OD, No Brine Tank, Media Separate	11168A
CP 216s OD, Empty, No Brine Tank	11186

Brine Tank Options

Tank Description	24" x 40"
Brine Tank Part Number	10586A
Material	HDPE
Salt Capacity	500 lbs.

Regeneration Specifications

Regeneration Volume / Time	160 gallons / 90 minutes
Backwash Flow Control	7.00 gpm
Brine Refill Flow Control	0.70 gpm

Overdrive Operation

Setting	Capacity	Efficiency	Dosing	Meter Disc
24 lbs.	88,000 grains	3,700 gr./lb.	6.0 lbs./ft ³	
40 lbs.	112,000 grains	2,800 gr./lb.	10.0 lbs./ft ³	
Peak flow during regeneration:				
				35 35 35 35 26.7 21.1 17.1 14.1

Alternating Operation

Setting	Capacity	Efficiency	Dosing	Meter Disc
24 lbs.	88,000 grains	3,700 gr./lb.	6.0 lbs./ft ³	
40 lbs.	112,000 grains	2,800 gr./lb.	10.0 lbs./ft ³	
Flow during regeneration (@ 15 psig):				
				15,192 7,596 5,064 3,798 3,038 2,532 2,170 1,899
Gallons/Regeneration:				

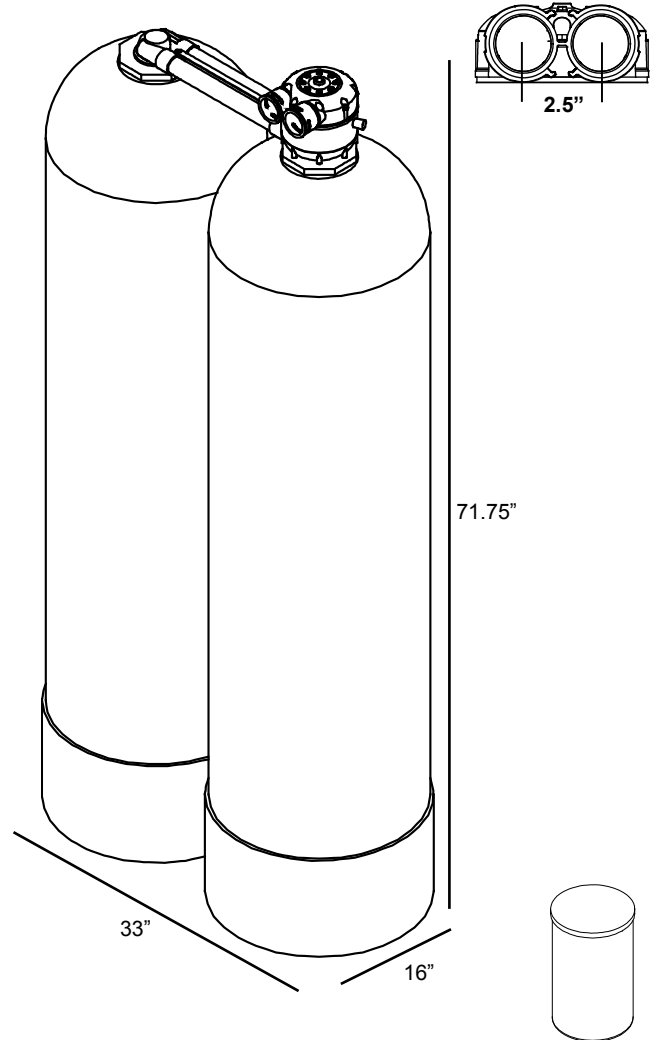

Disc Selection

(Compensated Hardness*)

1	2	3	4	5	6	7	8
5	9	13	16	19	22	25	30
6	12	16	21	25	30	35	40
35	35	35	35	26.7	21.1	17.1	14.1

1	2	3	4	5	6	7	8
5	10	15	20	25	30	35	40
7	13	20	26	32	38	43	49
23	23	23	23	23	21.1	17.1	14.1
15,192	7,596	5,064	3,798	3,038	2,532	2,170	1,899

*Compensated hardness in gpg = Hardness + (3 x Fe in mg/L)

Operating Profile

Softener shall remove hardness to less than 1/2 gpg when operated in accordance with the operating instructions. The system shall include two tanks. This duplex configuration shall be flexible to operate in alternating or parallel mode depending on installed program disc. In alternating mode, one tank will be on-line during service. In parallel mode, both tanks will be on-line during service. With either mode, during regeneration cycles, one tank shall provide water to service and to the regenerating tank. A water meter shall initiate system regeneration. The water meter shall measure the processed volume and be adjustable. Service flow shall be downflow and regeneration flow shall be upflow.

Regeneration Control Valve

The regeneration control valve shall be top mounted (top of media tank), and manufactured from non-corrosive materials. Control valve shall not weigh more than four pounds. Control valve shall provide service and regeneration control for two media tanks. Inlet and outlet ports shall accept a quick connect, double O-ring sealed adapter. Interconnection between tanks shall be made through the regeneration valve with a quick connect adapter. Control valve shall operate using a minimum inlet pressure of 25 psi. Pressure shall be used to drive all valve functions. No electric hook-up shall be required. Control valve shall incorporate four operational cycles including; service, brine draw, slow rinse, and a combined fast rinse and brine refill. Service cycle shall operate in a downflow direction. The brine cycle shall flow upflow, opposite the service flow, providing a countercurrent regeneration. Control valve shall contain a fixed orifice eductor nozzle and self-adjusting backwash flow control. The control valve will prevent the by-pass of hard water to service during the regeneration cycle.

Media Tanks

The tanks shall be designed for a maximum working pressure of 125 psi and hydrostatically tested at 300 psi. Tanks shall be made of polyethylene and reinforced with a fiberglass wrapping. Each tank shall include a 4.0 in. threaded top opening and a 2.5" x 4.0" tank adapter fitting. Each tank shall be NSF approved. Upper and lower distribution system shall be of a slot design. Distributors will provide even flow of regeneration water and the collection of processed water.

Conditioning Media

Each softener shall include a non-solvent, high capacity cation resin having a minimum exchange capacity of 30,000 grains/ft³ when regenerated with 15.0 lbs/ft³. The media shall be solid, of a proper particle size and shall contain no plates, shells, agglomerates or other shapes, which might interfere with the normal function of the water softener.

Brine System

A combination salt storage and brine production tank shall be manufactured of corrosion resistant, plastic. The brine tank shall have a chamber to house the brine valve assembly. The brine float assembly shall allow for adjustable salt settings and shall provide for a shutoff to the brine refill. The brine tank shall include a safety overflow connection to be plumbed to a suitable drain.